

R44[®] RAVEN & CLIPPER HELICOPTERS



R44[®] RAVEN HELICOPTERS

ROBINSON'S R44 RAVEN SERIES provides excellent reliability, responsive handling, and altitude performance, making the R44 the ideal helicopter for private, business, and utility applications.

A powder-coated steel-tube structure gives the R44 a strong, yet lightweight airframe while a streamlined fuselage enhances air speed and fuel economy. The R44 comfortably seats four adults, and passenger views are unobstructed due to the R44's open cabin design. A low tail-rotor tip speed, heavy-duty muffler, and large cambered tail decrease flyover noise, resulting in a community friendly helicopter.

RAVEN II

The high-performance R44 Raven II has a Lycoming IO-540 fuel injected, angle-valve, tuned-induction engine, which eliminates the need for carburetor heat. The standard 28-volt electrical system ensures good starting performance in hot or cold weather, and provides additional electrical power for optional equipment. Aerodynamic rotor blade tips reduce the 500-foot flyover noise level by nearly one decibel.

RAVEN I

Equipped with a Lycoming O-540 carbureted engine, the R44 Raven I offers a balance between performance and affordability. Raven I features carburetor heat assist that enhances safety and reduces pilot workload by automatically adjusting carburetor heat in response to power changes by the pilot.



The price-performance ratio makes the R44 Raven I an excellent flight trainer.



R44 Raven II delivers increased altitude performance.

PATENTED T-BAR CYCLIC

The R44's center-positioned, teetering T-bar cyclic makes it easy to enter and exit the cockpit. Left-seat flight controls are removable.

PISTOL-GRIP CYCLIC

Ergonomic cyclic grips incorporate two-position trigger switches for intercom and transmit. Pilot-side grip has buttons for convenient storing and switching of COM frequencies.

OPTIONAL UPGRADES

AIR CONDITIONING

Exclusive to the Raven II, the air conditioning system features front and rear vents to circulate cool air throughout the cabin.

To ensure maximum aircraft performance, the air conditioner compressor automatically disengages when the engine nears full throttle. The air conditioning system weighs 33 pounds and has a 12,000 Btu/hr cooling capacity.

PILOT'S AVIONICS CONSOLE

Places a GPS unit in an easy-to-see and reach position for the pilot to minimize the time spent looking down at the center instrument stack. The console accommodates a GPS, GPS/COM, or GPS/COM/NAV.

XENON HID LANDING LIGHTS

Xenon High Intensity Discharge (HID) lights provide superior illumination. HID bulb life exceeds 2000 hours.

IFR TRAINER

A specially designed instrument flight training package to prepare and qualify IFR pilots.

LEATHER INTERIOR

Seating available in tan, blue, and gray Italian leathers.

BOSE AVIATION HEADSETS

Lightweight headsets with noise reduction and enhanced audio clarity.

RAVEN II COCKPIT

Shown with 7-hole instrument panel and optional Pilot's Avionics Console



← Shaded area indicates footprint of optional 9-hole instrument panel

FEATURES



R44 Raven II Interior shown with optional leather seats and air conditioning.

HYDRAULIC POWER CONTROLS

Eliminates stick shake and control forces, enabling precise hovering and a smooth ride even at high speed.

RPM GOVERNOR

Monitors engine speed and adjusts the throttle automatically to maintain optimal RPM.

AUTOMATIC CLUTCH ENGAGEMENT

Simplifies the starting procedure and reduces the possibility of an overspeed during startup.

AVIONICS

COM radio and transponder are standard. A variety of Bendix/King and Garmin avionics upgrades are available.

VOICE-ACTIVATED INTERCOM

Removes the need for intercom switches.

MAIN ROTOR BLADES

A stainless steel spar at the leading edge resists dust and rain erosion. Droop stops prevent, under normal operating conditions, excessive main rotor teetering while stopping or starting the main rotor.

ROTOR BRAKE

Enables the pilot to stop the rotor blades more quickly, reducing shutdown time and risk of injury to bystanders.

SIMPLE TO MAINTAIN, EASY TO SERVICE

The R44 requires only 50-hour oil changes and standard 100-hour inspections. Main and tail rotor drive systems use maintenance-free couplings. Primary controls actuate by bellcranks and push-pull tubes, eliminating cables and pulleys. Fuselage access panels simplify pre-flighting and servicing of the helicopter.

2200-HOUR TIME-BETWEEN-OVERHAUL

Properly maintained, the R44 has an approved engine and airframe TBO of 2200 hours or 12 years. All life-limited components have approved service lives of at least 2200 hours or 12 years.

BAGGAGE COMPARTMENTS

R44 owners receive handsome, soft-sided travel and document bags designed to fit in the concealed storage area under each seat. Additional matching luggage pieces are available.



WARRANTY

All R44s have a two-year or 1000-hour limited aircraft warranty.

WORLDWIDE SERVICE

Robinson-approved service centers are located throughout the world to provide quality service using certified Robinson parts and tools.



R44[®] RAVEN HELICOPTERS

SPECIFICATIONS

SPECIFICATION	RAVEN II	RAVEN I
Engine Type	Lycoming IO-540 fuel injected	Lycoming O-540 carbureted
Cylinders	6	6
Gross Weight	2,500 lb	2,400 lb
Empty Weight Equipped (including oil & avionics)	1,500 lb	1,442 lb
Standard Fuel (30.6 gal)	184 lb	184 lb
Auxiliary Fuel (18.3 gal)	110 lb	110 lb
Passengers and Baggage with Standard Fuel	816 lb	774 lb
Cruise Speed ¹	up to 135 mph (117 kts)	up to 130 mph (113 kts)
Maximum Range (no reserve) ¹	up to 350 miles	up to 350 miles
Hover Ceiling IGE @ Gross Weight	8,950 ft	6,400 ft
Hover Ceiling OGE @ 2300 lb	7,500 ft	4,000 ft
Rate of Climb	over 1,000 fpm	over 1,000 fpm
Maximum Operating Altitude	14,000 ft	14,000 ft
7-Hole Instrument Panel	standard	standard
Electrical System	28V	14V
Air Conditioning	optional	not available

¹ For comparison purposes only, actual results may vary

DIMENSIONS

Apply to both Raven II and Raven I

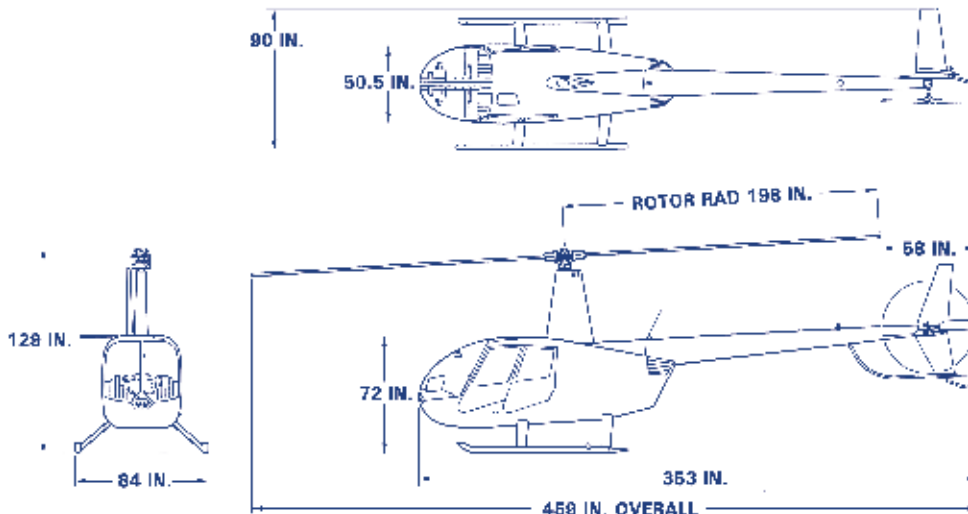

STANDARD INSTRUMENTS

- Airspeed indicator
- Altimeter
- Ammeter
- Carburetor temperature gage (Raven I)
- Cylinder head temperature gage
- Digital outside air temperature gage
- Hourmeter
- Magnetic compass
- Manifold pressure gage
- Oil temperature & pressure gages
- Quartz clock
- Rotor/engine dual tachometer
- Vertical speed indicator

WARNING LIGHTS

- Alternator
- Clutch actuator
- Engine fire
- Low fuel
- Low oil pressure
- Low rotor RPM (light and horn)
- Main gearbox temperature
- Main gearbox chip
- Rotor brake engaged
- Starter engaged
- Tail rotor gearbox chip

STANDARD EQUIPMENT

- Anti-collision light
- Auxiliary fuel system
- Belly hardpoint
- Cabin heater and defogger
- Carbon monoxide detector
- Door locks
- Dual landing lights
- Floor and hand intercom switches
- Ground handling wheels
- Navigation, panel, and map lights
- Oil filter and engine oil quick drain
- Pilot-side adjustable pedals
- Rotor blade tie downs
- Tinted windscreen and windows
- Tow cart adapter
- Windshield cover

R44[®] CLIPPER HELICOPTERS

ROBINSON'S R44 CLIPPERS are Ravens equipped with seaworthy floats and corrosion protection for over-water operations. The Clipper's low center-of-gravity provides excellent stability on water, and the float design enables safe emergency water landings and takeoffs. Special ground-handling wheels are included with each Clipper.

FIXED-UTILITY FLOATS

Available for both the Clipper I and Clipper II, fixed-utility floats add approximately 50 pounds to the aircraft's empty weight. Fixed-utility floats remain fully inflated and reduce cruise speed by approximately ten knots.

POP-OUT FLOATS

Available only on the Clipper II, pop-out floats have the same buoyancy as fixed-utility floats. The compact, low profile design minimizes the floats' impact on the helicopter's cruise speed and makes it easy to get in and out of the helicopter. Pop-out floats add 65 pounds to the helicopter's empty weight and when not inflated stow in snug sleeves along the skid tubes. A trigger on the collective deploys the floats, which inflate from a compressed helium-filled, carbon-fiber tank located under the left front seat.



R44 Clipper II, with pop-out floats stowed, on a residential rooftop helipad.



R44 Clipper I shown shipboard with optional rotor blade supports and frame tie-down lugs.

ROBINSON[®] QUALITY MANUFACTURING

Robinson manufactures, assembles, inspects, and flight tests all of its helicopters at its California factory. The factory features state-of-the-art equipment including computer numerically controlled (CNC) machining centers, electrical discharge machines (EDMs), and water jet and laser cutting machines. Robinson utilizes Coordinate Measuring Machines (CMMs) that can check dimensional tolerances within 3 microns or 120 millionths of an inch. This level of precision is essential to the fabrication of interchangeable parts, which are fundamental for the R44's hydraulic power controls.

To maximize efficiency, a large percentage of parts are made in-house. This allows Robinson to maintain a higher level of quality control, monitor production schedules and eliminate unnecessary costs.



Robinson's 480,000 square foot facility.



Flight test



CNC machining centers

ROBINSON HELICOPTER COMPANY

2901 Airport Drive • Torrance, CA • 90505 • USA
Phone: 310-539-0508 • Fax: 310-539-5198 • www.robinsonheli.com